

Response[™]

Wired Colour Camera(s) and 2 Channel Digital Video Recorder (DVR) CCTV CWK2/CWK3



Installation and Operating Instructions

These instructions should be retained in a safe place for future reference.

CONTENTS

1	INTRODUCTION	3	7	SYSTEM CONFIGURATION	16
2	KIT CONTENTS	4	8	TROUBLE SHOOTING	17
3	FEATURES	5	9	TECHNICAL SPECIFICATION	18
4	INSTALLATION	6	10	ACCESSORIES IN THE RANGE	20
4.1	System Connection	6	11	DISPOSAL – RECYCLING INSTRUCTIONS	21
4.2	Camera(s) Installation	7	12	GUARANTEE AND CUSTOMER HELPLINE	22
5	PANEL INTRODUCTION	9			
6	OPERATION	10			
6.1	Keys - Functions	10			
6.2	Changing Between Real Time Viewing and Playback Mode	11			
6.3	Channel Selection	11			
6.4	Manually Taking a Photo Shot or a Video Clip	11			
6.5	Menu Icons Definition	12			
6.6	System Setup	12			
6.6.1	Date/Time Setup	13			
6.6.2	Motion Detection and Advance Setup	13			
6.7	Playing Back Recorded Photos/Video Clips	14			
6.8	Memory Overwrite Indication	15			
6.9	Deleting Recorded Files	15			

Please read before you start:

Always use discretion when installing CCTV surveillance equipment especially when there is perceived policy. Enquire regarding local regulations applicable to the lawful installation of video recording/surveillance. Third party consent may be required.

The Response 2 Channel DVR Camera(s) Kit is a monitoring system designed to capture photos or 10 second video clips of any motion viewed by the camera(s) and store them in memory. It allows up to 2 wired cameras to connect to it. The wired cameras are colour, weatherproof and suitable for day/night use. They easily connect to your DVR for the protection of your home, office, etc.

SAFETY AND INSTALLATION TIPS:

DVR

- Keep away from heat sources and high temperature places, above 40°C
- Avoid direct sunlight
- Avoid humid places
- **Avoid vibration**
- Install in a ventilated environment

Camera(s) and DVR

Do not attempt to open the units with the power adaptor plug connected to avoid any risk of personal injury.

When installing CCTV camera(s), always follow manufacturer's advice when using power tools, steps, ladders, etc. and wear suitable protective equipment (e.g. safety goggles) when drilling holes. Before drilling holes through walls check for hidden electricity cables and water pipes. The use of a cable/pipe detector is advisable.

When installing any cameras with this unit, it is advisable to use cable conduit to protect any video/power extension cables from being exposed externally and to prevent/reduce the chances of the cables being tampered with. After drilling any hole through an external wall for a cable, ensure the hole is sealed up around the cable using a sealant to prevent drafts.

To prevent a fire or electrical shock hazard, do not attempt to open the housing while the unit is exposed to rain, water or wet conditions. There are no user serviceable parts inside. Refer servicing to qualified service personnel.

NIGHT VISION:

The cameras have built-in infra-red LEDs to allow you to view at night for 24hrs surveillance. The LEDs will automatically activate at night and the picture viewed will turn to black and white.

CWK2:

- 1 x 2 Channel DVR unit
- 1 x Wired Colour Camera
- 1 x 10m extension cable
- 1 x DIN to RCA adaptor lead assembly
- 1 x Video output to TV cable (1m)
- 1 x Power supply adaptor for DVR unit (12V/1.2A)
- 1 x Power supply adaptor for camera (12V/300mA)
- 1 x SD memory card (2GB)
- 1 x Camera fixings kit
- 2 x Window stickers
- 1 x Installation and operating manual

CWK3:

- 1 x 2 Channel DVR unit
- 2 x Wired Colour Cameras
- 1 x 10m extension cable
- 1 x 20m extension cable
- 1 x DIN to RCA adaptor lead assembly
- 1 x Video output to TV cable (1m)
- 1 x Power supply adaptor for DVR unit (12V/1.2A)
- 2 x Power supply adaptors for cameras (12V/300mA)
- 1 x SD memory card (2GB)
- 1 x Window sticker
- 2 x Camera fixings kit
- 1 x Installation and operating manual

Tools Required:

- Electric drill
- 5mm masonry drill bit
- 20mm masonry drill bit
- No. 2 Philips screwdriver
- 3mm flat blade screwdriver

- 2 channel video input/1 channel video output
- SD card technology
- Photos recorded in JPG format/video recorded in AVI format
- Motion detection
- Preset NTSC/PAL system input
- Time and date stamp
- Picture in picture display (view one camera channel in another camera channel)

4.1 System Connection

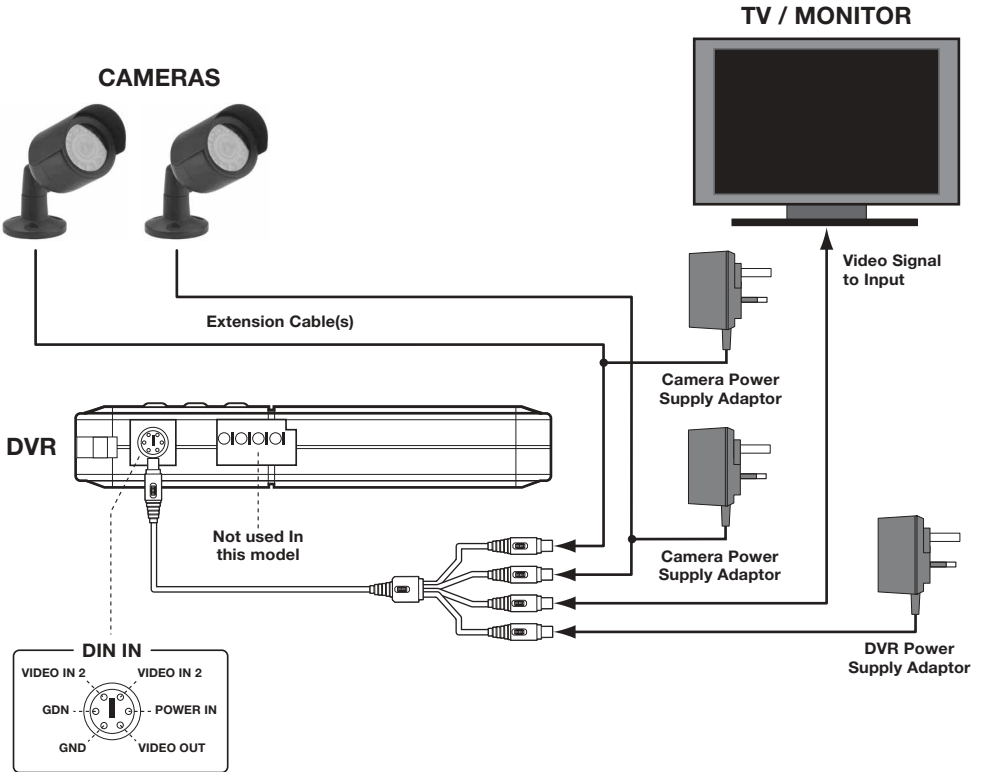

Key to DIN plug colours:

- White plug – Camera channel 1
- Yellow plug – Camera channel 2
- Black plug – Video output
- Red plug – 12VDC power in

Note: If this DVR is used with the Wireless Camera and Receiver Kit (CWFK1) the video output from the receiver is connected to the camera channel 1 or 2 plugs to view the wireless camera.

4.2 Camera(s) Installation

1. Remove the bracket from the camera by unscrewing it from the main body as shown below:

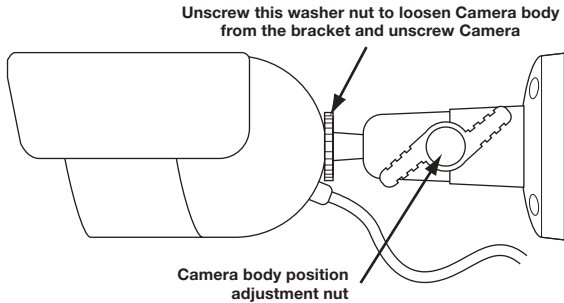

2. Use the base of the camera's bracket to mark out the 3 mounting holes on the chosen surface. Mark out a hole for the cable connectors to pass through into the property next to the camera.

Note: It is recommended to pass the cable into the property as close to the camera as possible to reduce the chances of any exposed cables being tampered with. If you choose to run the cable along the wall outside the property, it is recommended to use cable conduit to hide the cable and reduce the chances of it being tampered with.

3. Drill 3 x 5mm mounting holes for the bracket's wall plugs and 1 x 20mm hole for the camera's power and video connectors to pass through the wall.
4. Install the camera bracket using the supplied wall plugs and screws.
5. Feed the video/power leads through the hole in the wall, starting with the largest connector, and then refit the camera on to the bracket and adjust the position of the camera body as required by loosening the adjustment screw.
6. The camera is supplied fitted with a 1m cable terminated with a RCA female plug and a female power connector.
7. Connect the male end of the power connector from the extension cable into the camera along with the male RCA connector.
8. Connect the RCA video end of the extension cable into video input plug of your DVR. If only one camera is connected to the DVR, then connect this to the channel 1 plug (white colour).

9. Insert the SD card into the DVR if not already fitted.
10. Turn ON the DVR using the power switch.
11. Tune your TV to auxiliary (AUX), A/V or video mode to view the camera.
(**Note:** Refer to your TV/VCR/DVR's owner's manual for setting this up).
12. Adjust the camera again if necessary to the desired viewing angle.

Note: If the supplied extension cable is not long enough, the extension cable for a camera can only be extended up to **30m** in total length due to power loss.

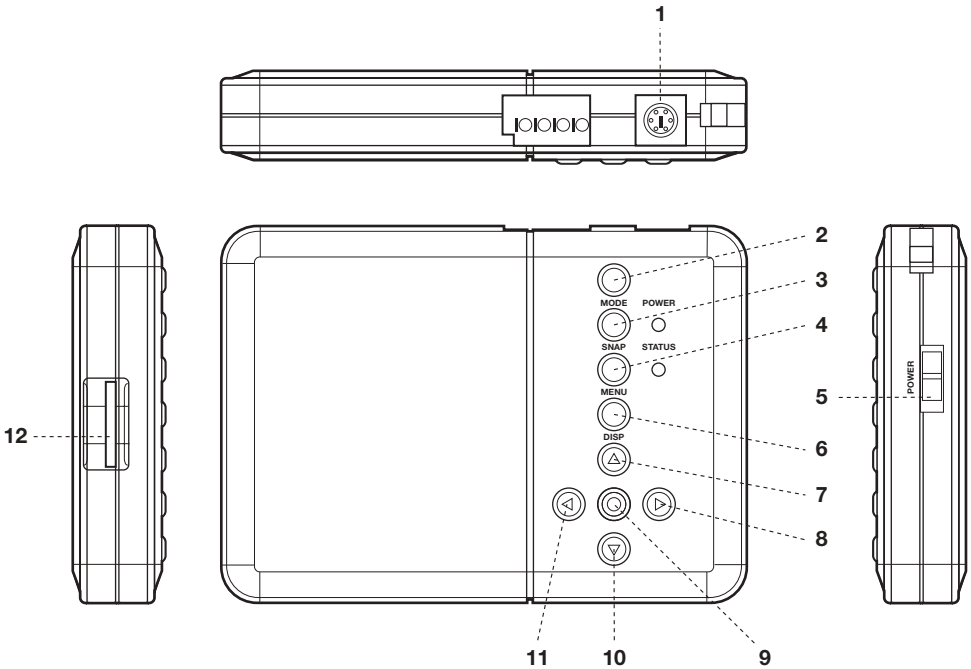

Key to controls:

- 1. DIN IN
(2 channel video input;
2 channel output;
12VDC/1.2A Power IN)
- 2. MODE Key
- 3. SNAP Key
(Take Photo or Record)
- 4. MENU Key
- 5. Power ON/OFF Switch
- 6. DISP (Display) Key
- 7. ▲ Up Key
- 8. ► Right Key
- 9. ● Enter Key
- 10. ▼ Down Key
- 11. ◀ Left Key
- 12. SD Card

6.1 Keys - Functions

Reference to diagram	Key	Real time mode (Live viewing)	Play back mode	Setup menu
2	Mode	Switch to play back mode	Switch to real time mode	
4	Menu	Setup menu	Delete files menu appears (for video clips, the Menu key only functions at the beginning or end of a clip)	Exit setup menu
9	Enter (or OK)		Display full screen of a selected photo shot or exit full screen	Confirm an item
6	Display	Switch between channel 1 and channel 2. If in photo mode then view one channel in another (picture in picture)		
3	Snap	Take a photo or record a video Clip		
11	Left		Move to left photo/ video clip	Move to left item. Select the motion detect area. Move the motion detect area to left
8	Right		Move to right photo/ video clip	Move to right item. Select the motion detect area. Move the motion detect area to right

7	Up	Motion detect ON/OFF (Indicated on the top left of the TV/monitor by an 'eye' sign)	Move up to a photo/video clip. Before playing back a file, the on screen display details can be removed or restored	Move the motion detect area/sensitivity up when adjusting
10	Down	Select photo or video record mode (Indicated on the top left of the TV/monitor by a photo camera or video camera sign)	Move down to a photo/video clip. Play back a selected video clip	Move the motion detect area/sensitivity down when adjusting

6.2 Changing Between Real Time Viewing and Playback Mode:

By default the DVR is set to view real time and will display channel 1 when powered ON. Press the MODE key to switch between real time and playback mode.

6.3 Channel Selection:

1. Press DISP to change from channel 1 to channel 2.
2. Press DISP again to view channel 2 in channel 1 (only the when DVR is set to photo record mode).
3. Press DISP again to view channel 1 in channel 2 (only when the DVR is set to photo record mode).
4. Press DISP again to return to channel 1 (only when DVR is set to photo record mode).

Note: In photo record mode, when one channel is viewed in another channel, the DVR will only record from the main viewing channel. In video record mode, it is not possible to view one channel in another.





6.4 Manually Take a Photo Shot or Video Clip:

Press the Down key to select photo or video mode. On the top left corner of your TV/monitor, you will see either the photo camera or video camera icon depending on your selection.

Press the SNAP key to capture a photo or video clip (fixed 10 second clip).

6.5 Menu Icons Definition:

Setup Screen

	Date Time Setup		Advance Setup
	Motion Detect On or Off		Quit Menu
	Select Photo or Video		

Advance Setup











 	Select TV System, NTSC or PAL	 	Select Image Quality High or Low
	Motion Detect Area Setting		Motion Detect Count
	Motion Detect Interval Setting		Motion Detect Sensitivity

Photo Management

	Delete One Photo		Format Memory, Clear All Files
	Delete All Photos		

6.6 System Setup:

1. During real time mode, press the MENU key to enter the setup menu.

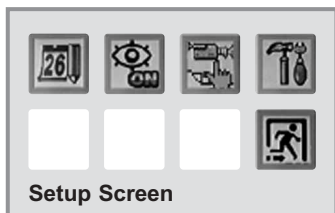

6.6.1 Date/Time Setup

- 1.1 Use the left/right key to select the 'Time Setup' icon and press enter.
- 1.2 Use the left/right key to select the date or time. Use the up/down key to set the correct digit.
- 1.3 Press enter to confirm settings.

6.6.2 Motion Detection and Advance Setup

When the DVR is set to motion detect, it records the photo or video by sensing any change in picture from the selected camera and stores on to an SD memory card. Although two cameras might be connected to the unit, it will only record from the selected camera channel. The time and date of the capture are also recorded.

- 1.4 Use the left/right key to move to the '**Motion Detect**' icon and press enter to enable/disable auto capture.
- 1.5 Use the left/right key to move to the '**Capture Format**' icon and press enter to select 'Photo' or 'AVI' (video). Note that the AVI video clips are fixed at a 10 second period.
- 1.6 Use the left/right key to move to the '**Setup**' icon and press enter.
- 1.7 Press enter to select the TV system, NTSC or PAL.
- 1.8 Use the left/right key to move to the image '**Quality**' icon and press enter to select high or low quality.
- 1.9 Use the left/right key to move to the '**Motion Detect Area (M)**' icon and press enter. Use the left/right key to select the detection area (full/middle/small area). Press enter to confirm the setting.
- 1.10 Use the left/right/up/down key to move the chosen detect area to a desired target position. Press enter to confirm the setting and exit the area setup.
- 1.11 Use the left/right key to move to the '**Motion Detect Count**' icon. This is used to set the number of photos the DVR will take for every trigger when the DVR is set to photo capture mode. The settings are 1/3/5 photo shots. Press enter to select the required number of shots.

- 1.12 Use the left/right key to move to the **'Motion Detect Interval'** icon. For photo capture format mode only, this is used to set the interval break in seconds between each capture (for example, if set to 5, then after the first trigger, it would take 5 seconds for the DVR to trigger again). Press enter to select 1/3/5 seconds. It is recommended to set to 1 for maximum event capture.
- 1.13 Use the left/right key to move to **'Motion Detect Sensitivity'** icon and press enter. The sensitivity range is 1~99. The larger the value the lower the sensitivity. Use the up/down key to adjust the 'Target Value' to the desired setting. The recommended setting is 10, however observe if this is too sensitive.

Movement is captured by the change in picture displayed on the TV/monitor in the selected area. If there are any changes in light such as a reflections, movement of tree branches, bushes for example, this can cause the system to start recording, although no approaching objects/persons may be seen during playback. If the sensitivity is set too high, natural activity such as rain for example may cause the system to start recording. It is also ideal to point the camera away from trees, bushes that might be affected by the wind. If any unnecessary photo/videos are captured adjust the sensitivity lower and observe.

If this DVR at any stage is used with a Wireless Camera and Receiver Kit (CWFK1) to receive wireless video, ensure this video viewed on the TV is the best possible reception (i.e, no interference lines viewed on the TV) between the camera and receiver. If necessary reduce the distance between the camera and receiver to prevent any interference on the picture. This is important to prevent the DVR from capturing any unnecessary recordings of interference when set to motion record. You may find that that if the wireless camera is installed outside the property, then maximum operating range without interference may be no more than 10m (provided only single brick wall acts as a barrier between the camera and receiver).

6.7 Playing Back Recorded Photos/Video Clips:

The photos or videos captured will be stored in different folders for easy searching. The folders are named according to the date sequence. If there are no file(s) in the memory, the DVR will display 'NO FILE' and return to real time viewing mode.

1. Press the MODE key to enter or exit playback.
2. Press the enter key to enter thumbnail view. Press again to enter full screen normal view.

3. Use the left/right key to move back or forward to an image or video clip.
4. To play back a video, press the Down key in full screen mode to play the video file
5. In full screen view, press the Up key to turn ON/OFF the on screen display information (date, time, capture number, etc). For video files ensure you select this before playing back the file.
6. Press DISP to view any folders and Up/Down keys to scroll to a folder and press enter to select.

6.8 Memory Overwrite Indication:

When the memory has reached its maximum storage capacity, any further files captured will overwrite the earliest file stored. When the system is overwriting the earliest file, this is indicated by the colour of the photo camera or video camera sign on the top left corner of the TV/monitor. It will turn red when overwriting.

6.9 Deleting Recorded Files:

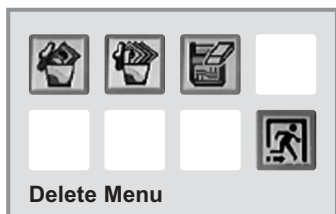

In play back mode, press the MENU key.

Use the left/right key to move to the required icon to delete the current image ('Delete One' icon), delete all files in the current folder ('Delete All' icon) or delete all files stored in memory ('Format' icon).

Press enter to display the tick or cross options for an icon on the screen. Use the left/right key followed by the enter key to select the chosen option.

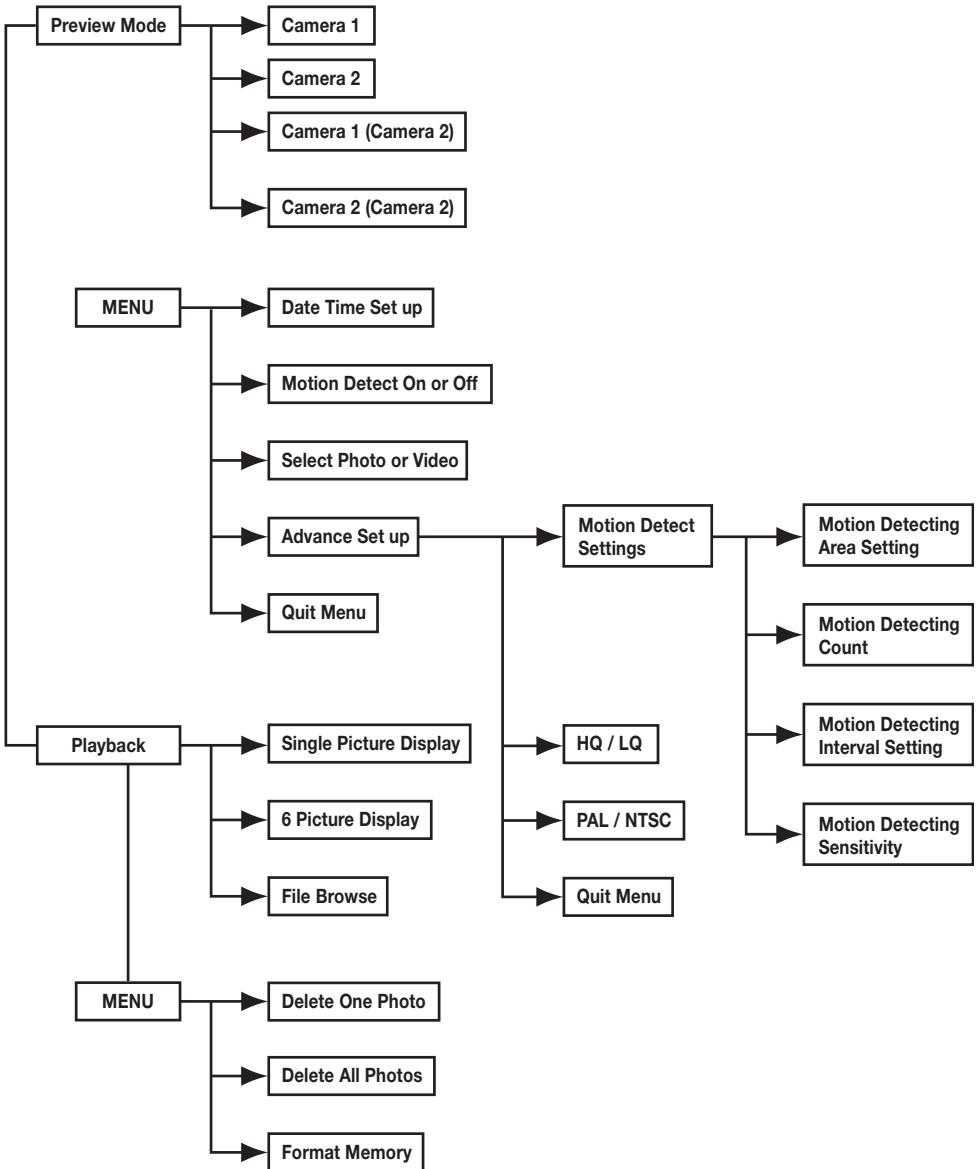

PROBLEM	SOLUTION
<i>No camera picture</i>	The power supply adaptor for the DVR or camera(s) is not plugged in. Check all video cable connections between the camera(s) and DVR. The TV is not tuned to view the correct channel.
<i>Poor picture quality</i>	Clean the camera lens. Adjust the contrast/brightness on the TV.
<i>Some colours viewed by the camera do not appear to look like true colours</i>	The camera's lens is a CMOS type sensor. Its limitation is that it will not produce all colours viewed outside accurately.
<i>A white image appears at night</i>	The camera's infra-red LEDs shine invisible light that reflects off surfaces such as glass causing white light. Place the camera on the other side of windows or place the lens flush against the surface to try to improve the night vision or place in a well lit area.
<i>DVR doesn't automatically record when set to motion record when movement is captured</i>	Ensure Motion Detection has been setup in the menu (see pages 11 and 12 or 13 and 14). Ensure the correct 'Motion Detect Interval' has been set correctly. (See page 14). Ensure the sensitivity is set correctly. (See page 14). Ensure the 'Motion Detect Area' has been set correctly. (See page 13).
<i>When set to motion record, the DVR seems to start recording without seeing any significant movement</i>	Point the camera away from tree branches or bushes which may sway in windy weather conditions. Heavy rain or snow may cause the DVR to start recording due to the movement of rain in bushes which may sway in windy weather the picture viewed. Changes in light could also cause this. Reduce the sensitivity if needed. (See page 14).
<i>The photo camera or video camera symbol on the top left corner of the screen has turned red</i>	This indicates the DVR will overwrite the earliest recorded information each time it records.

ITEM	2 CHANNEL DVR
Video format	PAL / NTSC
Video input	2 channel (NTSC / PAL) (RCA)
Video output	1 channel (NTSC/PAL) Composite video output
Video display	Single picture or picture in picture display
Display resolution	JPEG VGA: 640 x 480 AVI QVGA: 320 x 240; 5fps for 10 seconds
Compression method	JPEG
Image quality	High/Low
Motion detection	Programmable area and sensitivity settings
Hard disk	1 x Internal SD card
Storage capacity	Maximum 2GB SD card stores up to 20,000 photos and or records up to 12 hours of video per channel
Alarm output	Active low power signal output when motion is detected
Power supply	12V DC/1.2A output power supply adaptor
Power consumption	2.5W max.
Dimension of DVR (L x W x H)	140 x 100 x 25mm
Operating temperature	0 to 40°C

ITEM	WIRED CAMERA
Image sensor	1/4" colour CMOS
Video format	PAL / NTSC
Pixel resolution	PAL: 628 (H) x 582 (V) NTSC: 510 (H) x 492 (V)
Horizontal resolution	380 TV lines
Minimum illumination	0 lux when the IR lamps are turned on
Viewing angle	50°
Lens size	6mm
Night vision range	Up to 9m
Number of IR LEDs	11
IP rating	IP54
Operating temperature	- 10°C to 55°C
Power supply	12VDC/300mA
Cable type connections	Fitted with 1m video cable terminated with female RCA and female jack (power) plugs
Dimensions (W x D x H)	50 x 50 x 135mm
Weight	280g

There are a range of accessories available in the Response CCTV product range to expand your system:

CWK1	Wired Colour Camera CCTV Kit
CA2	LCD Screen for Wireless/Wired CCTV Kits
CWFK1	Wireless Colour Camera CCTV Kit
CA3	Wireless Colour Accessory Camera <i>(requires CWFK1 CCTV KIT to operate)</i>
CA5	Professional Heavy Duty Camera CCTV Kit
CA6	Dummy Professional Heavy Duty Camera
CA7	4 Channel DVR Recorder Kit
CA8	Wired Internal Colour Dome Camera CCTV Kit
CA9	Dummy Internal Dome Camera
CA10	Heavy Duty Colour Camera CCTV Kit
CA11	Dummy Heavy Duty Camera
CA4	10m Extension Cable Kit
CA12	20m Extension Cable Kit

Note: The maximum extension cable length for any wired camera with this system is **30m** without reducing the picture quality of the video.

Directive (2002/96/EC)

This product is classified by the Waste Electrical or Electronic Equipment (WEEE) Directive. It should not be disposed of with other household or commercial waste. At the end of its useful life the packaging and product should be disposed of via a suitable recycling centre. For information on available facilities, please contact your local authority or the retailer from where the product was purchased.



Novar ED&S undertakes to replace or repair at its discretion goods (excluding non rechargeable batteries) should they become defective within 1 year solely as a result of faulty materials and workmanship.

If the product has not been installed, operated or maintained in accordance with the instructions, has not been used appropriately or if any attempt has been made to rectify, dismantle or alter the product in any way the guarantee will be invalidated.

The guarantee states Novar ED&S entire liability. It does not extend to cover consequential loss or damage or installation costs arising from the defective product. This guarantee does not in any way affect the statutory or other rights of a consumer and applies to products installed within UK and Eire only.

If an item develops a fault, the product must be returned to the point of sale with:

1. Proof of purchase.
2. A full description of the fault.
3. All relevant batteries (disconnected).

Response is a trademark of Novar ED&S.

CUSTOMER HELPLINE

Most issues can be solved over the phone in a few minutes.

Please contact our Helpline Team on the number below for any installation and general advice regarding our products:

0844 736 9149

Lines open 9.00am to 5.00pm, Monday to Friday.

Calls charged at service providers national rate.



Novar Electrical Devices and Systems Limited. (A Honeywell Company)

The Arnold Centre, Paycocke Road, Basildon, Essex SS14 3EA. UK

www.friedland.co.uk