

Response[™]

Dummy Heavy Duty Camera CA11



Installation Instructions

These instructions should be retained in a safe place for future reference.

The Response Dummy Heavy Duty Camera is a non functioning unit, although it is identical in appearance to the Response Wired Heavy Duty Camera (CA10). It is intended for use as a visual deterrent to assist in the protection of your home, office, etc. The dummy camera is easily mounted on the wall using the supplied mounting bracket.

Please read before you start:

Always use discretion when installing CCTV surveillance equipment especially when there is perceived policy. Enquire regarding local regulations applicable to the lawful installation of video recording/surveillance. Third party consent may be required.

SAFETY AND INSTALLATION TIPS:

When installing any CCTV camera(s), always follow manufacturer's advice when using power tools, steps, ladders, etc. and wear suitable protective equipment (e.g. safety goggles) when drilling holes. Before drilling holes through walls check for hidden electricity cables and water pipes. The use of a cable/pipe detector is advisable.

KIT CONTENTS

- 1 x Dummy Heavy Duty Camera
- 1 x Camera fixings kit - wall plugs and screws
4 x Ø3.5mm x 27mm screws and 4 x No.8, 28mm wall plugs are supplied for the wall bracket.
- 1 x Installation manual
- 1 x Window sticker

Tools Required:

- Electric drill
- 5mm masonry drill bit
- No. 2 Philips screwdriver
- 3mm flat blade screwdriver

1. Use the camera's main bracket to mark out the x 4 mounting holes on the chosen location on the wall (Fig. 1).

Drill 4 x 5mm holes for the mounting bracket's wall plugs.

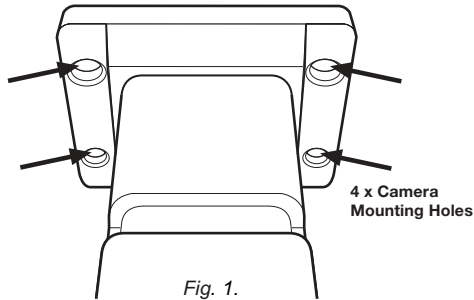

2. Screw the post bracket to the main housing and tighten the nut until secure (Fig. 2). Secure the lower part of the post on to the main bracket (Fig. 3). Mount the main bracket on to the wall using the fixing screws and wall plugs.

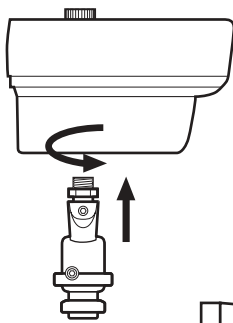

Fig. 2.

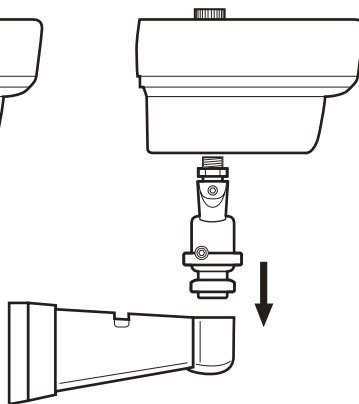

Fig. 3.

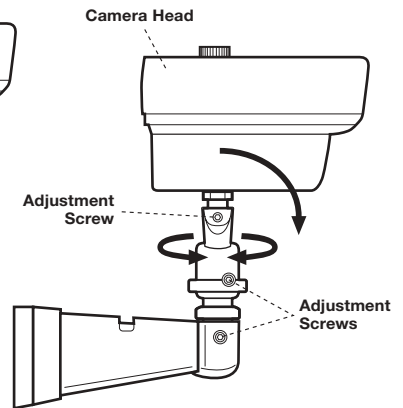

Fig. 4.

3. Adjust the camera head position as required and tighten all screws using the allen key tool supplied in the fixing kit. You can make adjustments to the camera head positions as shown (Fig. 4).

There are a range of accessories available in the Response CCTV product range to expand your system:

CWK1	Wired Colour Camera CCTV Kit
CA1	2 Channel Digital Video Image Recorder
CA2	LCD Screen for Wireless/Wired CCTV Kits
CWFK1	Wireless Colour Camera CCTV Kit
CA3	Wireless Colour Accessory Camera <i>(requires CWFK1 CCTV KIT to operate)</i>
CA5	Professional Heavy Duty Camera CCTV Kit
CA6	Dummy Professional Heavy Duty Camera
CA7	4 Channel Digital Video Image Recorder
CA8	Wired Internal Colour Dome Camera CCTV Kit
CA9	Dummy Internal Dome Camera
CA10	Heavy Duty Colour Camera CCTV Kit
CA4	10m Extension Cable Kit
CA12	20m Extension Cable Kit

DISPOSAL – RECYCLING INSTRUCTIONS

Directive (2002/96/EC)

This product is classified by the Waste Electrical or Electronic Equipment (WEEE) Directive. It should not be disposed of with other household or commercial waste. At the end of its useful life the packaging and product should be disposed of via a suitable recycling centre. For information on available facilities, please contact your local authority or the retailer from where the product was purchased.



Novar ED&S undertakes to replace or repair at its discretion goods (excluding non rechargeable batteries) should they become defective within 1 year solely as a result of faulty materials and workmanship.

If the product has not been installed, operated or maintained in accordance with the instructions, has not been used appropriately or if any attempt has been made to rectify, dismantle or alter the product in any way the guarantee will be invalidated.

The guarantee states Novar ED&S entire liability. It does not extend to cover consequential loss or damage or installation costs arising from the defective product. This guarantee does not in any way affect the statutory or other rights of a consumer and applies to products installed within UK and Eire only.

If an item develops a fault, the product must be returned to the point of sale with:

1. Proof of purchase.
2. A full description of the fault.
3. All relevant batteries (disconnected).

Response is a trademark of Novar ED&S.

CUSTOMER HELPLINE

Most issues can be solved over the phone in a few minutes.

Please contact our Helpline Team on the number below for any installation and general advice regarding our products:

0844 736 9149

Lines open 9.00am to 5.00pm, Monday to Friday.

Calls charged at service providers national rate.



Novar Electrical Devices and Systems Limited. (A Honeywell Company)

The Arnold Centre, Paycocke Road, Basildon, Essex SS14 3EA. UK

www.friedland.co.uk