

MA12 - Dusk/Dawn Lampholder

Installation and Operating Instructions

These instructions should be retained in a safe place for future reference.

Kit Contents:

- 1 x Dusk/Dawn Lampholder,
(Bayonet fitting)
- 1 x Instruction Leaflet

Not suitable for use with Low Energy Fluorescent lamps.

For use with B22 Bayonet fitting lamps rating 60-100Wmax only.

For use on 240V/50Hz only.

SAFETY

Always ensure that the lighting circuit is switched OFF before installation or changing the bulb.

Do not exceed the maximum bulb rating for this product, light fitting or any lamp shade fitted.

Ensure that there is adequate ventilation around the adaptor and that any lamps shade fitted are not covered.

Take care when removing the bulb as it may be very hot.

This product is suitable for mounting in dry locations only.

INTRODUCTION

The Dusk/Dawn Lampholder will provide security lighting in an indoor location by automatically switching the lamp on at Dusk and off again at Dawn. A sensor cover allows the unit to be overridden to switch the light on during the day if required. The cover also allows the amount of light reaching the sensor to be controlled to cater for various lighting conditions.

POSITIONING

The sensor should be positioned so that it is not facing a reflective surface, (e.g. a mirror) as too much reflected light may cause the lamp to continuously flicker.

The sensor should be positioned so that it receives adequate natural daylight.

The sensor must not be illuminated by any external light source.

INSTALLATION

- 1) Turn off the supply to the light fitting and remove the bulb and lampshade from the conventional lampholder.
- 2) Unscrew the skirt and fit the lampshade to the Dusk/Dawn Lampholder between the locking ring and skirt. **DO NOT REMOVE THE LOCKING RING.**
- 3) Fit the Dusk/Dawn Lampholder and shade to the conventional lampholder.
- 4) Replace the bulb in the Dusk/Dawn Lampholder.

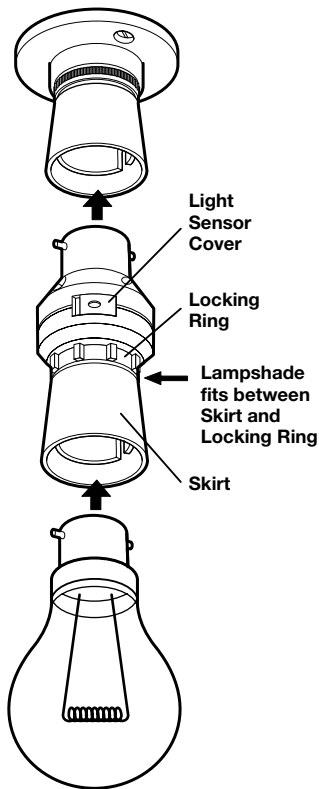

OPERATION

For automatic operation, turn the light switch controlling the fitting ON and slide the sensor cover to the OFF position.

When the ambient light level falls at Dusk the lamp will turn ON.

When the ambient light level increase again at Dawn the lamp will turn OFF.

Note: At Dusk and Dawn when the ambient light is very close to the switching point of the device the lamp may flicker for a short period. This is normal and is not a fault.

TESTING

The unit should be tested during daylight.

- 1) Ensure that the light switch controlling the fitting is switched ON.
- 2) Slide the sensor cover to the OFF position and the lamp should switch ON.
- 3) Slide the sensor cover to the ON position and the lamp should switch OFF.

TROUBLE SHOOTING

Lamp Does Not Turn ON at Dusk
- Location not dark enough or illuminated by other light sources

- Reposition sensor so that it is in a darker position.
- Remove external light source

Lamp Does Not Turn OFF at Dawn

- Location too dark and does not get enough natural light.
- Ensure sensor cover is in OFF position.
- Reposition sensor so that it is in a lighter position.

Lamp Continuously Flickers - too much reflected light on sensor

- Reposition sensor so that it is not pointing at source of reflection.
 - Remove source of reflection, (note: light may also be reflected by frosted glass lamp shades).
 - Adjust the sensor cover so that it partially covers the sensor to reduce amount of light seen by sensor.
-

GUARANTEE

Novar ED&S undertakes to replace or repair at its discretion goods (excluding non rechargeable batteries) should they become defective within 2 years solely as a result of faulty materials and workmanship. Understandably if the product has not been installed, operated or maintained in accordance with the instructions, has not been used appropriately or if any attempt has been made to rectify, dismantle or alter the product in any way the guarantee will be invalidated.

The guarantee states Novar ED&S entire liability. It does not extend to cover consequential loss or damage or installation costs arising from the defective product. This guarantee does not in any way affect the statutory or other rights of a consumer and applies to products installed within the UK and Eire only.

If an item develops a fault within the first year, it should be returned to the point of sale with:

- 1) Proof of purchase.
- 2) A full description of the fault.
- 3) All relevant batteries (disconnected).

In the second year it should be returned direct to Friedland Technical Sales Services Department at the address shown below.

Friedland is a trademark of Novar ED&S.

HELPLINE

If you have any problems with your alarm, please call the Helpline on:

01268 563273

(Lines open 9.00am to 5.00pm, Monday to Friday)



Friedland, Novar Electrical Devices and Systems

The Arnold Centre, Paycocke Road, Basildon, Essex. SS14 3EA
www.friedlandsecurity.com